

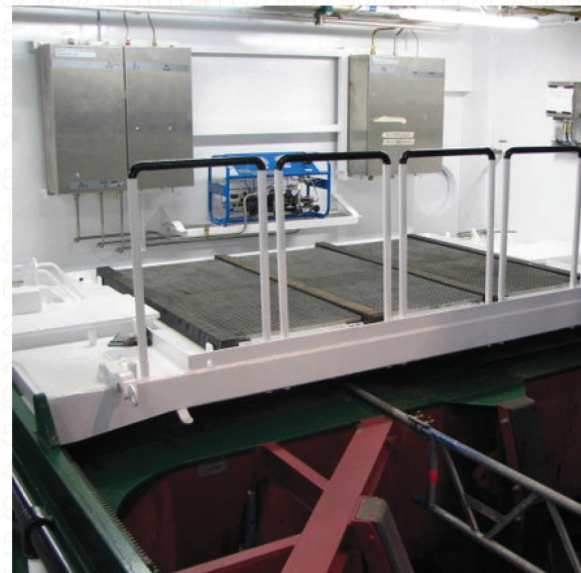

Offshore, Maritime & Industrial Solutions

Solutions For Offshore Vessels

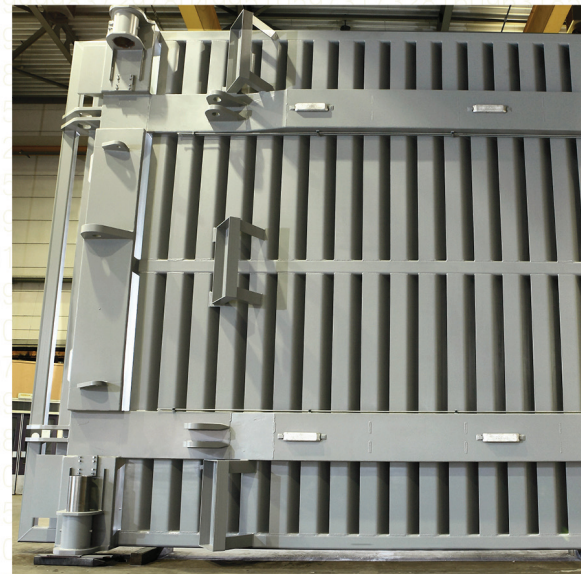

Technical Information

ROV Door

Moonpool Door

Moonpool Top Hatch

Solutions For Offshore Vessels

The Parosha Innovators door and hatch solutions are designed to meet the high standards and demands of customers around the world.

Parosha Innovators B.V. supplies moonpool doors, moonpool hatches and ROV doors for a diversity of vessel types such as, but not limited to: cable-laying vessels, dive-support vessels, research vessels, exploration vessels, platform supply vessels and more. Over the years Parosha Innovators B.V. has designed offshore solutions for several major customers worldwide.

The Parosha Innovators doors and hatches are tailor made to the customers' requirements. The equipment can be supplied with certificates of all major classification societies such as Lloyd's Register, ABS, DNV GL, BV.

ROV Door

The Parosha ROV door is developed to protect the personnel and launch- and recovery system (LARS) equipment. The patented design ensures safe operation in extreme environments and under harsh conditions.

Due to its patented design the door will stay parallel to the hull during operation. This ensures safe operation in high sea-states and high winds. Trouble-free operation of the ROV door is a requirement to ensure continuous ROV operations.

The design is such that high quality is assured and a minimum of maintenance is needed. The standard design can be tailor made to the customers need.

The standard design ensures the supply of reliable equipment that has proven itself already in several projects.

Types

The ROV door can be supplied as a 1 piece fully closed door, 2 piece fully closed door or as a partial lower door in



combination with an overhead roller door.

The ROV doors can be designed to open to the aft or to the front, depending on the requirements. A seal is used to ensure weather tightness when the door is closed and secured.

In order to determine the best solution for your application, we need the following data: a drawing of the surrounding area of the door, dimensions of the clear opening.

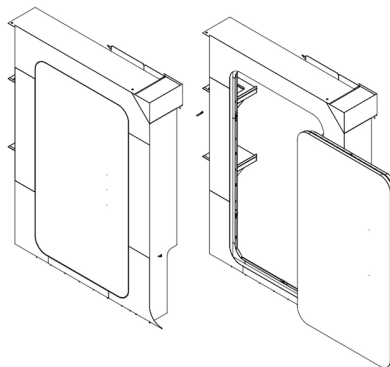

Operation

The ROV doors are operated with hydraulic cylinders.

Sensors are used to indicate the positions of the ROV door and the status of the locking pins. A dedicated hydraulic system with a control box can be supplied.

When two ROV doors are used on a vessel (PS and SB), the controls can be combined in one control box or a dedicated control box for each door can be supplied. Integration in to the LARS control system for easy operation is also one of the options.

Design

High tensile steel is used for the construction of the ROV door to ensure a high level of structural integrity. The hinges are fitted with maintenance free bearings.



Hydraulic operated locking pins are used to secure the door to suit the weather tightness of the ROV door.

Indication lights are placed on the control box to monitor the safe operation of the ROV door.



As an option, signals can be sent to a bridge indication panel or to the LARS operation system.

Moonpool Door

A moonpool door is used to close off the opening where the moonpool intersects the vessel shell. Due to the design of the Parosha moonpool door, the waves and turbulence in the moonpool door are significantly reduced. This results in a save operation of the moonpool and more efficiency of the vessel resulting in fuel saving.

The Parosha Innovators moonpool door is not watertight. The specially designed Z-profiles allow water to flow freely in and out the moonpool. This reduces the forces on the moonpool door caused by the water. This profile also reduce wave formation and turbulence in the moon pool.

The moonpool door is based on a standard design and is tailor made to the requirements of your specific situation. Structures in the moonpool, such as cursor rails can be taken in to account so the moonpool door can be adapted to this.

Types

The Parosha moonpool doors can be designed to close the complete moonpool area or just a part of the moon pool. The moonpool door can be of one piece or split into two pieces, depending on the available space and the requirements of the costumer. In opened position, the moonpool door will be stored in a recess in the moonpool. This ensures a maximum available moonpool opening for the equipment.

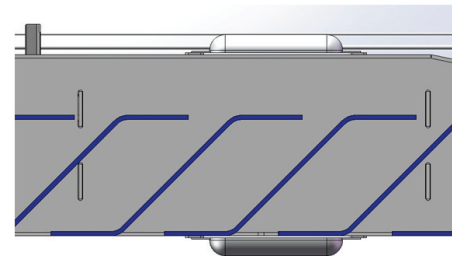
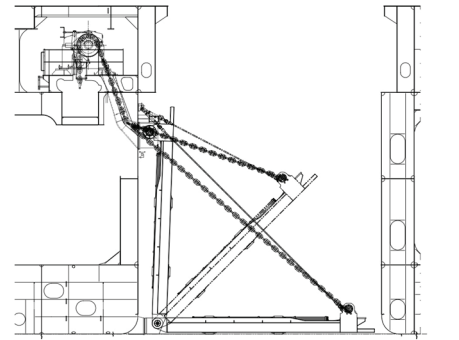

Operation

The moonpool door can be operated with a winch and chain or with hydraulic cylinders.

When operated with a winch and chain, a chain with the required length will be supplied. The winch with necessary hydraulics is yard supply. If the moonpool door is operated with hydraulic cylinders, a dedicated hydraulic system can be supplied for the main- and locking cylinders.

The moonpool door will be locked in the open and closed position with hydraulic actuated locking pins. The locking pin arrangements are located on the moonpool door.

Sensors are placed on the locking pin arrangements to monitor the position of the locking pins. To monitor the position of the moonpool door an angle transmitter is used.

Design

High tensile steel is used for the construction of the moonpool door to ensure a high level of structural integrity. The hinges are fitted with bronze bearings. Hydraulic operated locking pins are used to secure the moonpool door in the open and closed position.

Indication lights are placed on the control box to monitor the safe operation of the moonpool door.

As an option, signals can be sent to a bridge indication panel or to the LARS operation system.

Moonpool Top Hatch

A moonpool top hatch is used to close the moonpool when the moonpool is not used. This ensures a safe environment for the crew between moonpool operations. The Parosha moonpool top hatch can also be designed to store for example a ROV or diving bell.

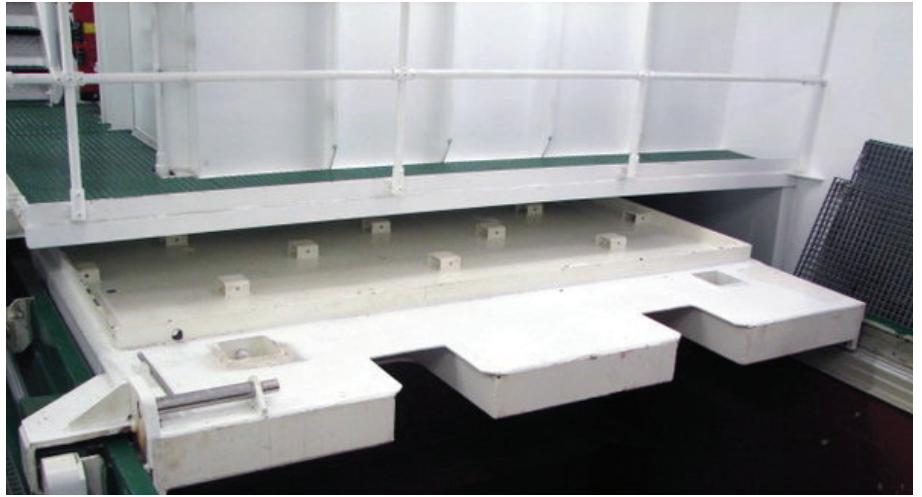

The moonpool top hatch is based on a standard design and is tailor made to meet the requirements of your specific situation. Structures in the moonpool, such as cursor rails can be taken in to account so the moonpool top hatch can be adapted to this.

Types

Parosha Innovators B.V. can supply several types of moonpool top hatches. The available types are: sliding, opening downwards & opening upwards. The sliding moonpool top hatch can be used to store a ROV or diving bell and transport this equipment in the hangar. If space is limited, the hatch can slide under the deck structure, see the figure on top of the page.

The moonpool top hatches opening downwards or upwards are of a similar design with the difference in the direction of opening.

The downwards opening moonpool top hatch will be stored in a recess in the moonpool. This ensures a maximum available moonpool opening for the equipment.

Operation

The moonpool top hatches are operated with hydraulic- cylinders or motors. A dedicated hydraulic system for the moonpool top hatch can be supplied. The sliding moonpool top hatch can be locked with manual operated locking pins.



The up- and downwards opening moonpool doors are locked with hydraulic actuated locking pins.

Sensors are provided to monitor the open and closed position of the moonpool top hatches and the status of the hydraulic operated locking pins.

Design

High tensile steel is used for the construction of the moonpool top hatch to ensure a high level of structural integrity.

The hinges are fitted with bronze bearings. Locking pins are used to secure the moonpool top hatch door in the open and closed position. Indication lights are placed on the control box to monitor the safe operation of the top hatch door. As an option, signals can be sent to a bridge indication panel or to the LARS operation system.



Parosha Innovators B.V. is a globally active as leading supplier and manufacturer of fully integrated technical solutions for the offshore, maritime and industrial sectors. Parosha Innovators B.V. is an in the Netherlands-based, privately held company and is part of the Parosha Group.

Published by Parosha Innovators B.V. Copyright © Parosha Innovators B.V. April 2015. All rights reserved. No part of this publication may be reproduced, stored, photocopied, recorded or transmitted without permission of the copyright owner.

Parosha Innovators B.V.
Nij Toerenburg 20
9076 MA Sint Annaparochie
The Netherlands

tel. +31 58 767 6290
info@parosha.com
www.parosha.com